

## Wavin UK (Holdings) Ltd

Parsonage Way  
Chippenham  
Wiltshire SN15 5PN  
Tel: 01249 654121 Fax: 01249 443286  
e-mail: info@wavin.co.uk  
website: www.wavin.co.uk



Agrément Certificate  
**87/1835**  
Product Sheet 4

## OSMADRAIN UNDERGROUND DRAINAGE SYSTEM

### INSTALLATION

#### PRODUCT SCOPE AND SUMMARY OF CERTIFICATE

This Certificate relates to the installation of the OsmaDrain Underground Drainage System.

#### Installation

#### 1 General

Installation should be carried out in accordance with BS 8000-14 : 1989, BS EN 1610 : 1998, BS EN 752 : 2008, Water UK/WRC plc publication *Sewers for Adoption*, 6th edition, and this Certificate.

#### 2 Laying pipes

On trench bottom in granular material (see Figure 1)

2.1 Where the as-dug material is suitable<sup>(1)</sup> for use as bedding, the bottom of the trench may be trimmed to form the pipe bed.

(1) Suitable material is defined in BS EN 1610 : 1998, section 5.3.2

2.2 Small depressions should be made to accommodate the pipe sockets or couplings. After the pipe has been laid these should be carefully filled to ensure that no voids remain under, or around, the socket.

2.3 When the formation is prepared, the pipes should be laid upon it true to line and level within the specified tolerances. Each pipe should be checked and any necessary adjustments to level made by raising or lowering the formation, ensuring that the pipes finally rest evenly on the adjusted formation throughout the length of the barrels. Adjustment should never be made by local packing.

2.4 Where the formation is low and does not provide support, it should be brought up to the correct level by placing and compacting suitable material.

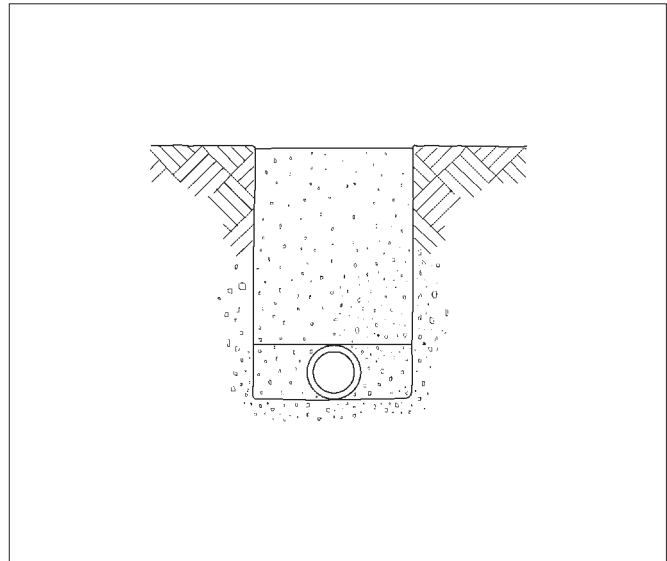

The BBA has awarded this Agrément Certificate to the company named above for the system described herein. This system has been assessed by the BBA as being fit for its intended use provided it is installed, used and maintained as set out in this Certificate.

On behalf of the British Board of Agrément

Date of First issue: 5 October 2010

Originally certificated on 11 May 1987

Brian Chamberlain

Head of Approvals — Engineering

Greg Cooper

Chief Executive

*The BBA is a UKAS accredited certification body — Number 113. The schedule of the current scope of accreditation for product certification is available in pdf format via the UKAS link on the BBA website at [www.bbacerts.co.uk](http://www.bbacerts.co.uk)*

*Readers are advised to check the validity and latest issue number of this Agrément Certificate by either referring to the BBA website or contacting the BBA direct.*

British Board of Agrément

Bucknalls Lane  
Garston, Watford  
Herts WD25 9BA

tel: 01923 665300  
fax: 01923 665301  
e-mail: mail@bba.star.co.uk  
website: [www.bbacerts.co.uk](http://www.bbacerts.co.uk)

©2010

## On granular beds (see Figures 2 and 3)

2.5 When the as-dug material is not suitable as a bedding, a layer of suitable granular material as defined in BS EN 1610 : 1998, section 5.3.3.1, must be spread evenly on the trimmed trench bottom before the pipes are installed. The trench should be excavated to allow for a minimum thickness of 100 mm granular bedding under the pipes (see Figure 3).

2.6 The trench formation should be prepared, the bedding placed and the pipes laid in accordance with BS EN 1610 : 1998 and BS 8000-14 : 1989.

2.7 Where the as-dug material can be hand trimmed by shovel and is not puddled when walked upon, a 50 mm depth of bedding material may be used. In this case the material must be nominal 10 mm single sized aggregate with no sharp edges, ie pea gravel (see Figure 2).

2.8 When the pipes are to be laid on rock, compacted sand or gravel requiring mechanical means of trimming should be used, or, in very soft or wet ground, the bedding should be as detailed in section 2.5.

Figure 1 Pipes laid on trench bottom

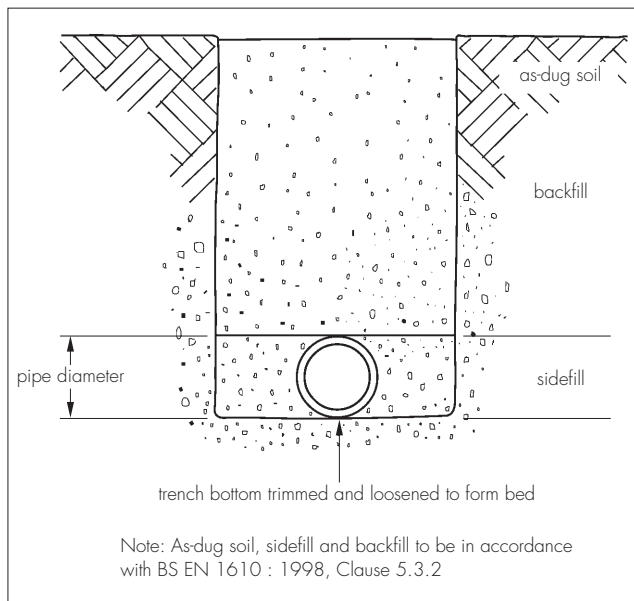

Figure 2 Pipes laid on 50 mm minimum pea gravel bedding

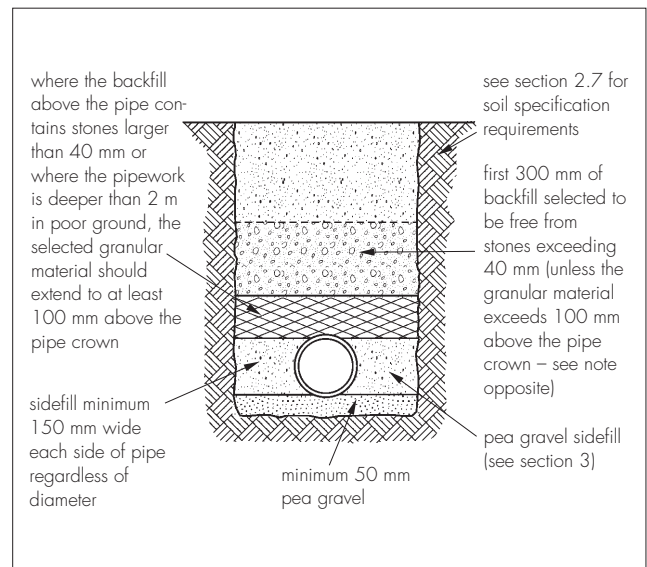
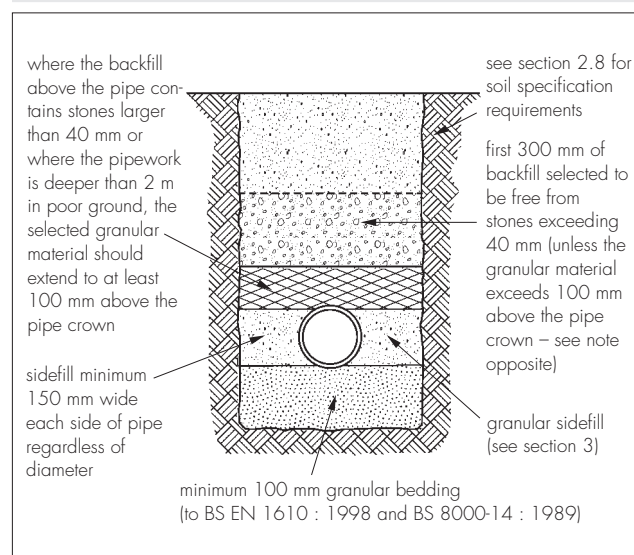

Figure 3 Pipes laid on 100 mm minimum granular bedding



## 3 Sidefill

In all cases the sidefill must be of the same specification as the bedding material, extend to the level of the crown of the pipe and be placed and compacted in accordance with BS EN 1610 : 1998 and BS 8000-14 : 1989.

## 4 Backfill

Backfill above the level of the crown of the pipe must be in accordance with BS EN 1610 : 1998, section 5.4 (see Figures 1, 2 and 3).

## Bibliography

BS 8000-14 : 1989 *Workmanship on building sites — Code of practice for below ground drainage*

BS EN 752 : 2008 *Drain and sewer systems outside buildings*

BS EN 1610 : 1998 *Construction and testing of drains and sewers*

## 5 Conditions

### 5.1 This Certificate:

- relates only to the product/system that is named and described on the front page
- is granted only to the company, firm or person named on the front page — no other company, firm or person may hold or claim any entitlement to this Certificate
- is valid only within the UK
- has to be read, considered and used as a whole document — it may be misleading and will be incomplete to be selective
- is copyright of the BBA
- is subject to English law.

5.2 Publications and documents referred to in this Certificate are those that the BBA deems to be relevant at the date of issue or re-issue of this Certificate and include any: Act of Parliament; Statutory Instrument; Directive; Regulation; British, European or International Standard; Code of Practice; manufacturers' instructions; or any other publication or document similar or related to the aforementioned.

5.3 This Certificate will remain valid for an unlimited period provided that the product/system and the manufacture and/or fabrication including all related and relevant processes thereof:

- are maintained at or above the levels which have been assessed and found to be satisfactory by the BBA
- continue to be checked as and when deemed appropriate by the BBA under arrangements that it will determine
- are reviewed by the BBA as and when it considers appropriate.

5.4 In granting this Certificate, the BBA is not responsible for:

- the presence or absence of any patent, intellectual property or similar rights subsisting in the product/system or any other product/system
- the right of the Certificate holder to manufacture, supply, install, maintain or market the product/system
- individual installations of the product/system, including the nature, design, methods and workmanship of or related to the installation
- the actual works in which the product/system is installed, used and maintained, including the nature, design, methods and workmanship of such works.

5.5 Any information relating to the manufacture, supply, installation, use and maintenance of this product/system which is contained or referred to in this Certificate is the minimum required to be met when the product/system is manufactured, supplied, installed, used and maintained. It does not purport in any way to restate the requirements of the Health & Safety at Work etc Act 1974, or of any other statutory, common law or other duty which may exist at the date of this Certificate; nor is conformity with such information to be taken as satisfying the requirements of the 1974 Act or of any statutory, common law or other duty of care. In granting this Certificate, the BBA does not accept responsibility to any person or body for any loss or damage, including personal injury, arising as a direct or indirect result of the manufacture, supply, installation, use and maintenance of this product/system.